

- I** Bruciatori policombustibile gasolio/gas
- GB** Dual fuel light oil/gas burners
- F** Brûleurs mixtes fioul/gaz
- D** Mehrstoffbrenner Heizöl/Gas
- E** policombustible gasóleo/gas

Funzionamento bistadio progressivo o modulante lato gas / bistadio lato gasolio  
Oil progressive two-stage or modulating operation / Gas two-stage operation  
Fonctionnement fioul à deux allures progressives ou modulant / Fonctionnement gaz à deux allures  
Zweistufiger gleitender oder modulierender Betrieb für Öl / Zweistufig für Gas  
Funcionamiento a dos llamas progresivas o modulante lado gas / a dos llamas lado gasóleo

<b>CODICE - CODE CODIGO</b>	<b>MODELLO - MODEL - MODELE MODELL - MODELO</b>	<b>TIPO - TYP TYPE</b>
3898000 - 3898010	RLS 68/M MX	779 T
3898001 - 3898011	RLS 68/M MX	779 T
3898100 - 3898110	RLS 120/M MX	780 T
3898101 - 3898111	RLS 120/M MX	780 T

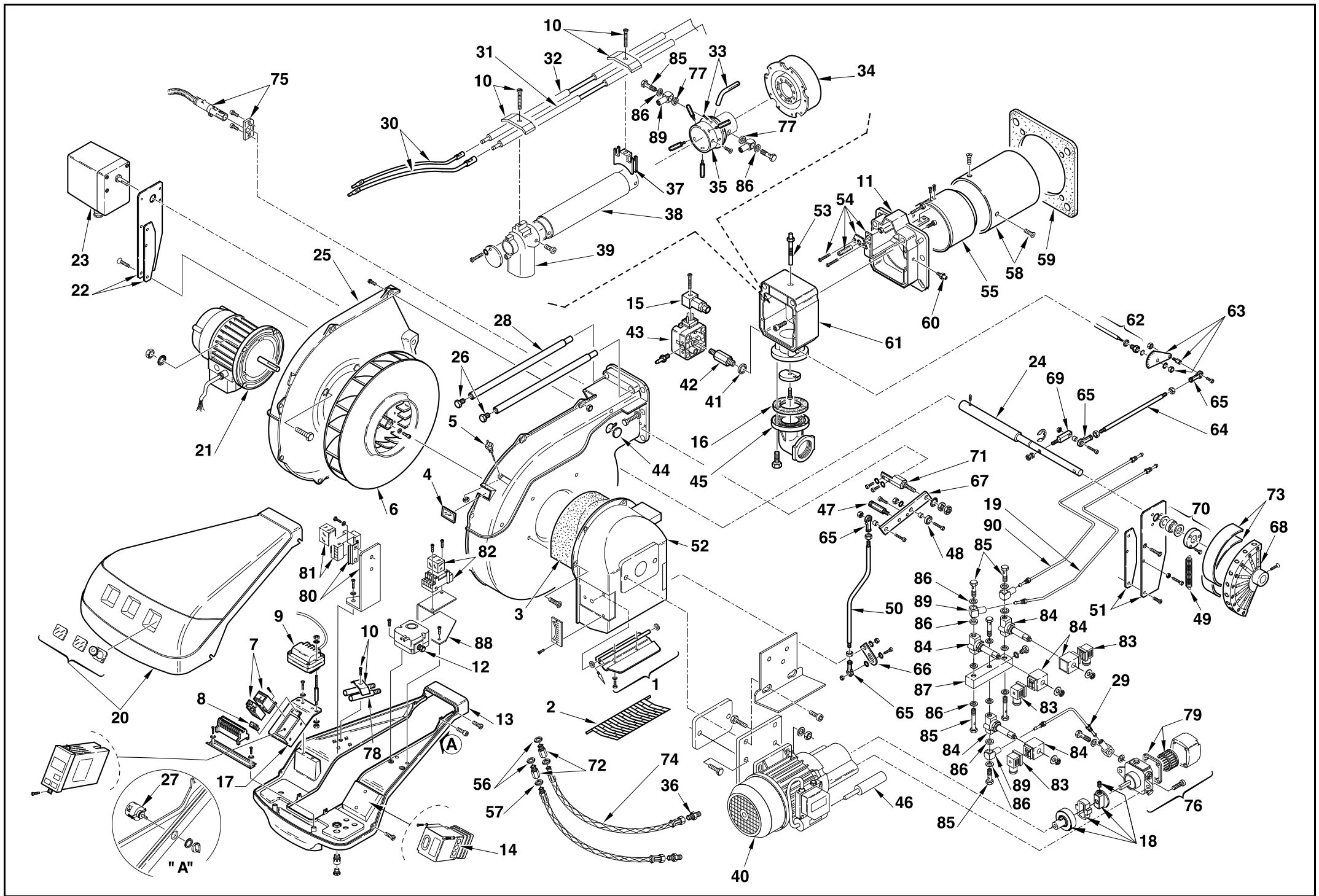

N.	COD.	779 T	779 T *	780 T	780 T *	DESCRIZIONE	DESCRIPTION	DESCRIPTION	BESCHREIBUNG	DENOMINACION	MATRICOLA BRUCIATORE BURNER SERIAL NUMBER MATRICULE BRULEUR BRENNER KENN-NUMMER MATRICULA QUEMADORES	**
1	3003948	●	●	●	●	GRUPPO SERRANDA	AIR DAMPER ASSEMBLY	GROUPE VOLET AIR	LUFTKLAPPE	CONJUNTO REGISTRO AIRE		
2	3003949	●	●	●	●	PROTEZIONE	GRID	PROTECTION	SCHUTZGITTER	PROTECION		
3	3003952	●	●	●	●	FONOASSORBENTE	SOUND DAMPING	INSONORISANT	GERÄUSCHDÄMMUNG	AISLAMIENTO ACÚSTICO		
4	3003763	●	●	●	●	VISORE	INSPECTION WINDOW	VISEUR	SICHTFENSTER	VISOR		
5	3003891	●	●	●	●	RACCORDO	CONNECTOR	MAMELON	NIPPEL	RACORD		C
6	3003964	●	●			GIRANTE	FAN	TURBINE	GEBLÄSERAD	TURBINA		C
6	3012405			●	●	GIRANTE	FAN	TURBINE	GEBLÄSERAD	TURBINA		C
7	3003960	●	●			AVVIATORE	STARTER	DEMARREUR	ANLASSER	ARRANCADOR		C
7	3003961			●	●	AVVIATORE	STARTER	DEMARREUR	ANLASSER	ARRANCADOR		C
8	3012080	●	●	●	●	INTERRUTTORE	SWITCH	INTERRUPTEUR	SCHALTER	INTERRUPTOR		
9	3003785	●	●	●	●	TRASFORMATORE	TRANSFORMER	TRANSFORMATEUR	ZÜNDTRANSFORMATOR	TRANSFORMADOR		B
10	3003409	●	●	●	●	PIASTRINA	PLATE	PLAQUETTE	ETRIER	PLATTE		
11	3012413	●	●	●	●	FRONTONE	FRONT PIECE	FACADE	VORDERTEIL	SOPORTE		
12	3007444	●	●	●	●	PRESSOSTATO ARIA	AIR PRESSURE SWITCH	PRESSOSTAT AIR	LUFTDRUCKWÄCHTER	PRESÓSTATO AIRE		A
13	3013171	●	●	●	●	MENSOLA	BASE PLATE	PLAQUE DE SUPPORT	GRUNDPLATTE	REPISA		
14	3006090	●	●	●	●	APPARECCHIATURA	CONTROL BOX	BOITE DE CONTROLE	STEUERGERÄT	CAJA CONTROL		B
15	3012347	●	●	●	●	PRESA	SOCKET	PRISE	STECKBUCHSE	CONECTOR		
16	3005482	●	●	●	●	GUARNIZIONE	SEAL	RONDELLE	FLANSCHDICHTUNG	JUNTA		C
17	3012343	●	●	●	●	SUPPORTO	SUPPORT	SUPPORT	HALTER	SOPORTE		
18	3003440	●	●	●	●	GIUNTO	JOINT	ACCOUPEMENT	PUMPENKUPPLUNG	ACOPLAMIENTO	≤ 02398XXXXXX	A
18	3013828	●	●	●	●	GIUNTO	JOINT	ACCOUPEMENT	PUMPENKUPPLUNG	ACOPLAMIENTO	≥ 02408XXXXXX	A
19	3013378		●		●	TUBO	TUBE	TUYAUTERIE	DRUCKROHR	TUBO		
19	3013385		●		●	TUBO	TUBE	TUYAUTERIE	DRUCKROHR	TUBO		
20	3013119	●	●	●	●	COFANO	COVER	COFFRET	VERKLEIDUNG	ENVOLVENTE		
21	3003967	●	●			MOTORE	MOTOR	MOTEUR	MOTOR	MOTOR		C
21	3003968	●	●	●	●	MOTORE	MOTOR	MOTEUR	MOTOR	MOTOR		C
22	3012585	●	●	●	●	PIASTRA	ANCHOR PLATE	PLATINE DE BLOCAGE	ARRETIERPLATTE	PLATINA		
23	3012345	●	●	●	●	SERVOMOTORE	SERVOMOTOR	SERVOMOTEUR	STELLMOTOR	SERVOMOTOR		B
24	3012349	●	●	●	●	ALBERO	SHAFT	ARBRE	WELLE	ARBOLILLO		
25	3012012	●	●	●	●	GUSCIO	HALF-SHELL	COUVERCLE	HAUBE	CÀSCARA		
26	3003481	●	●	●	●	VITE	SCREW	VIS	SCHRAUBE	TORNILLO		
27	3012310	●	●	●	●	COMMUTATORE	SELECTOR SWITCH	COMMUTATOR	WAHLSCHALTER	CONMUTADOR		C
28	3012213	●	●	●	●	PERNO	BAR	GLISSIERE	BOLZEN	PERNO		C
29	3013381	●	●	●	●	TUBO	TUBE	TUYAU	ROHR	TUBO		
30	3003795	●	●	●	●	COLLEGAMENTO ELETTRODO	H.T. LEAD	CONNEXION POUR ELECTRODE	VERBINDUNG FÜR ELEKTRODE	CABLE CONEXIÓN		A
31	3013371	●		●		ELETTRODO	ELECTRODE	ELECTRODE PORCELAINE	ELEKTRODE	ELECTRODO		A
31	3013382		●		●	ELETTRODO	ELECTRODE	ELECTRODE PORCELAINE	ELEKTRODE	ELECTRODO		A
32	3013370	●		●		ELETTRODO	ELECTRODE	ELECTRODE PORCELAINE	ELEKTRODE	ELECTRODO		A
32	3013383		●		●	ELETTRODO	ELECTRODE	ELECTRODE PORCELAINE	ELEKTRODE	ELECTRODO		A
33	3013377	●	●			TUBETTO	TUBE	TUYAU	RÖHRCHEN	TUBO		
33	3013376			●	●	TUBETTO	TUBE	TUYAU	RÖHRCHEN	TUBO		
34	3013372	●	●			TAZZA	AIR DIFFUSER	DIFFUSEUR D'AIR	FLAMMKOPFBECHER	DIFUSOR DEL AIRE		A
34	3013373			●	●	TAZZA	AIR DIFFUSER	DIFFUSEUR D'AIR	FLAMMKOPFBECHER	DIFUSOR DEL AIRE		A
35	3013375	●	●			DISTRIBUTORE	GAS HEAD	DISTRIBUTEUR	GASVERTEILER	DISTRIBUIDOR		
35	3013374			●	●	DISTRIBUTORE	GAS HEAD	DISTRIBUTEUR	GASVERTEILER	DISTRIBUIDOR		
36	3009068	●	●	●	●	RACCORDO	CONNECTOR	MAMELON	NIPPEL	RACORD		C
37	3013380	●	●	●	●	SUPPORTO	SUPPORT	SUPPORT	HALTER	SOPORTE		
38	3012038	●		●		TUBO ESTERNO	EXTERIOR TUBE	TUYAU EXTERIEUR	AUSSERER ROHR	TUBO EXTERNO		

N.	COD.	779 T	779 T *	780 T	780 T *	DESCRIZIONE	DESCRIPTION	DESCRIPTION	BESCHREIBUNG	DENOMINACION	MATRICOLA BRUCIATORE BURNER SERIAL NUMBER MATRICULE BRULEUR BRENNER KENN-NUMMER MATRICULA QUEMADORES	**
38	3012039		•		•	TUBO ESTERNO	EXTERIOR TUBE	TUYAU EXTERIEUR	AUSSERER ROHR	TUBO EXTERNO		
39	3012412	•	•	•	•	GOMITO	ELBOW	COUDE	SCHLITTEN	CODO		
40	3013180	•	•	•	•	MOTORE	MOTOR	MOTEUR	MOTOR	MOTOR	≤ 02436999999	C
40	3013829	•	•	•	•	MOTORE	MOTOR	MOTEUR	MOTOR	MOTOR	≥ 02446000000	C
41	3007166	•	•	•	•	GUARNIZIONE	SEAL	RONDELLE	METALLDICHTUNG	JUNTA		B
42	3003864	•	•	•	•	RACCORDO	CONNECTOR	MAMELON	NIPPEL	RACORD		C
43	3003660	•	•	•	•	PRESSOSTATO GAS	GAS PRESSURE SWITCH	PRESSOSTAT GAZ	GAS DRUCKWÄCHTER	PRESÓSTATO GAS		B
44	3003996	•	•	•	•	TAPPO	PLUG	BOUCHON A VIS	SCHRAUBSTÖPSEL	TAPÓN		
45	3006803	•	•	•	•	FLANGIA + GOMITO	FLANGE AND ELBOW	BRIDE ET COUDE	FLANSCH UND GASSCHLITTEN	BRIDA Y CODO		
46	3013182	•	•	•	•	CONDENSATORE	CONDENSER	CONDENSATEUR	KONDENSATOR	CONDENSADOR	≤ 02436999999	B
46	3013875	•	•	•	•	CONDENSATORE	CONDENSER	CONDENSATEUR	KONDENSATOR	CONDENSADOR	≥ 02446000000	B
47	3012352	•	•	•	•	PERNO	BAR	GLISSIERE	BOLZEN	PERNO		C
48	3003841	•	•	•	•	CUSCINETTO	BEARING	ROULEMENT	LAGER	COJINETE		
49	3012356	•	•	•	•	MOLLA	SPRING	RESSORT	FEDER	MUELLE		A
50	3012351	•	•	•	•	TIRANTE	TIE ROD	TIRANT	GESTÄNGE	TIRANTE		
51	3012594	•	•	•	•	PIASTRA	ANCHOR PLATE	PLATINE DE BLOCAGE	ARRETIERPLATTE	PLACA		
52	3012454	•	•	•	•	BOCCA D'ASPIRAZIONE	AIR INTAKE	BOITIER D'ASPIRATION	ANSAUGÖFFNUNG	BOCA DE ASPIRACIÓN		
53	3012049	•	•	•	•	VITE	SCREW	VIS	SCHRAUBE	TORNILLO		
54	3012414	•	•	•	•	GRUPPO REGOLATORE	CONTROL DEVICE	GROUPE OBTURATION	DRUCKREGULIERUNG	GRUPO REGULACION		
54	3012929		•		•	GRUPPO REGOLATORE	CONTROL DEVICE	GROUPE OBTURATION	DRUCKREGULIERUNG	GRUPO REGULACION		
55	3012416	•	•	•	•	OTTURATORE	SHUTTER	OBTURATEUR	SCHIEBER	OBTURADOR		C
56	3007079	•	•	•	•	GUARNIZIONE	SEAL	RONDELLE	METALLDICHTUNG	JUNTA		
57	3007088	•	•	•	•	GUARNIZIONE	SEAL	RONDELLE	METALLDICHTUNG	JUNTA		
58	3012415	•		•		IMBUTO FIAMMA	END CONE	EMBOUT GUEULARD	FLAMMENROHR	TUBO EXTREMO		B
58	3012930		•		•	IMBUTO FIAMMA	END CONE	EMBOUT GUEULARD	FLAMMENROHR	TUBO EXTREMO		B
59	3003991	•	•	•	•	SCHERMO	FLANGE GASKET	ECRAN THERMIQUE	FLASCHDICHTUNG	JUNTA AISLANTE		A
60	3003322	•	•	•	•	RACCORDO	CONNECTOR	MAMELON	NIPPEL	RACORD		C
61	3013368	•	•			MANICOTTO	MANIFOLD	MANCHON	GASANSCHLUSS	COLARIN		
61	3013369			•	•	MANICOTTO	MANIFOLD	MANCHON	GASANSCHLUSS	COLARIN		
62	3012059	•	•	•	•	ALBERO E ANELLO	SHAFT AND RING	ARBRE ET ANNEAU	WELLE UND RING	ARBOLILLO E ANILLO		
63	3012599	•	•	•	•	QUADRANTE	GRADUATE SECTOR	SECTEUR GRADUE	SKALENSEGMENT	SECTOR GRADUADO		
64	3012060	•	•	•	•	TIRANTE	TIE ROD	TIRANT	GESTÄNGE	TIRANTE		
65	3006098	•	•	•	•	SNODO SFERICO	PIN JOINT	CHAPE A ROTULE	KUGELGELENK	ARTICOLACION ESFERICA		C
66	3012359	•	•	•	•	LEVA	LEVER	LEVIER	HEBEL	PALANCA		C
67	3012354	•	•	•	•	LEVA	LEVER	LEVIER	HEBEL	PALANCA		C
68	3012358	•	•	•	•	CAMMA	CAM	CAME	NOCKEN	EXCÉNTRICO		
69	3012350	•	•	•	•	LEVA	LEVER	LEVIER	HEBEL	PALANCA		C
70	3012357	•	•	•	•	CUSCINETTO	BEARING	ROULEMENT	LAGER	COJINETE		
71	3012353	•	•	•	•	PERNO	BAR	GLISSIERE	BOLZEN	PERNO		
72	3005739	•	•	•	•	RACCORDO	CONNECTOR	MAMELON	NIPPEL	RACORD		
73	3006097	•	•	•	•	MOLLA	SPRING	RESSORT	FEDER	MUELLE		A
74	3009055	•	•	•	•	TUBO FLESSIBILE	FLEXIBLE OIL LINE	FLEXIBLE	ÖLSCHLAUCH	TUBO FLEXIBLE		A
75	3003396	•	•	•	•	FOTOCCELLULA	U.V. DETECTOR	PHOTOCELLULE U.V.	U.V. PHOTOZELLE	FOTORESISTENCIA		A
76	3003999	•	•	•	•	POMPA	PUMP	POMPE	PUMPE	BOMBA	≤ 02436999999	C
76	3013830	•	•	•	•	POMPA	PUMP	POMPE	PUMPE	BOMBA	≥ 02446000000	C
77	3003381	•	•	•	•	GUARNIZIONE	SEAL	RONDELLE	METALLDICHTUNG	JUNTA		B
78	3003956	•	•	•	•	PROLUNGA PERNO	BAR EXTENSION	RALLONGE DE GLISSIERE	VERLÄNGERUNG	PROLUNGACIÓN PERNO		
79	3003936	•	•	•	•	FILTRO + GUARNIZIONE	FILTER + SEAL	FILTRE + RONDELLE	FILTER + METALLDICHTUNG	FILTRO + COLLARIN		A

N.	COD.	779 T	779 T *	780 T	780 T *	DESCRIZIONE	DESCRIPTION	DESCRIPTION	BESCHREIBUNG	DENOMINACION	MATRICOLA BRUCIATORE BURNER SERIAL NUMBER MATRICULE BRULEUR BRENNER KENN-NUMMER MATRICULA QUEMADORES	**
80	3013189	•	•	•	•	SUPPORTO	SUPPORT	SUPPORT	HALTER	SOPORTE		
81	3013190	•	•	•	•	RELE' TERMICO	OVERLOAD	RELAIS THERMIQUE	ÜBERSTROMAUSLÖSER	RELÉ TÉRMICO		C
82	3012292	•	•	•	•	RELE' TERMICO	OVERLOAD	RELAIS THERMIQUE	ÜBERSTROMAUSLÖSER	RELÉ TÉRMICO		C
83	3006953	•	•	•	•	PRESA	HOLDER	PRISE CELLULE	SOCKEL	CONECTOR		
84	3012002	•	•	•	•	VALVOLA	NEEDLE VALVE	VANNE POINTEAU	NADELVENTIL	VÀLVULA		B
85	3003592	•	•	•	•	PERNO	BAR	GLISSIERE	BOLZEN	PERNO		C
86	3007077	•	•	•	•	GUARNIZIONE	SEAL	RONDELLE	METALLDICHTUNG	JUNTA		B
87	3012569	•	•	•	•	COLLETTORE	MANIFOLD	COLLECTEUR	SAMMLER	COLECTOR		
88	3012423	•	•	•	•	SUPPORTO	SUPPORT	SUPPORT	HALTER	SOPORTE		
89	3006722	•	•	•	•	RACCORDO	CONNECTOR	MAMELON	NIPPEL	RACORD		C
90	3013379	•	•	•	•	TUBO	TUBE	TUYAUTERIE	DRUCKROHR	TUBO		
90	3013384	•	•	•	•	TUBO	TUBE	TUYAUTERIE	DRUCKROHR	TUBO		

8458

\*

Versione Testa Lunga - Long Combustion Head Version - Version Tête Longue - Langer Brennkopf Ausführung - Versión alargado de tubo llama

\*\*

A = Ricambi per dotazione minima - Spare parts for minimum fittings - Pièces détachées pour équipement minimum - Ersatzteile für minimale Ausstattung - Recambios para equipamiento mínimo

A+B = Ricambi per dotazione base di sicurezza - Spare parts for basic safety fittings - Pièces détachées pour équipement standard de sécurité - Ersatzteile für Sicherheitsgrundausrüstung - Recambios para equipamiento básico de seguridad

A+B+C = Ricambi per dotazione estesa di sicurezza - Spare parts for extended safety fittings - Pièces détachées pour équipement complet de sécurité - Ersatzteile für erweiterte Sicherheitsausstattung - Recambios para equipamiento general de seguridad





---

**RIELLO**

RIELLO S.p.A.  
I-37045 Legnago (VR)  
Tel.: +39.0442.630111  
[http:// www.riello.it](http://www.riello.it)  
[http:// www.rielloburners.com](http://www.rielloburners.com)