

- I** Bruciatori policombustibile gasolio/gas
- GB** Dual fuel Gas-Oil/Gas burners
- F** Brûleurs mixtes fioul/gaz
- D** Mehrstoffbrenner Heizöl/Gas
- E** Quemadores policombustible gasóleo / gas

Funzionamento bistadio progressivo o modulante lato gas / bistadio lato gasolio
Oil progressive two-stage or modulating operation / Gas two-stage operation
Fonctionnement fioul à deux allures progressives ou modulant / Fonctionnement gaz à deux allures
Zweistufiger gleitender oder modulierender Betrieb für Öl / Zweistufig für Gas
Funcionamiento a dos llamas progresivas o modulante lado gas / a dos llamas lado gasóleo

CODICE - CODE CÓDIGO	MODELLO - MODEL - MODELE MODELL - MODELO	TIPO - TYPE - TYP
3898200 - 3898210	RLS 160/M MX	781 T
3898201 - 3898211	RLS 160/M MX	781 T
20011632 - 20011635	RLS 160/M MX	781 T
20011641 - 20011642	RLS 160/M MX	781 T

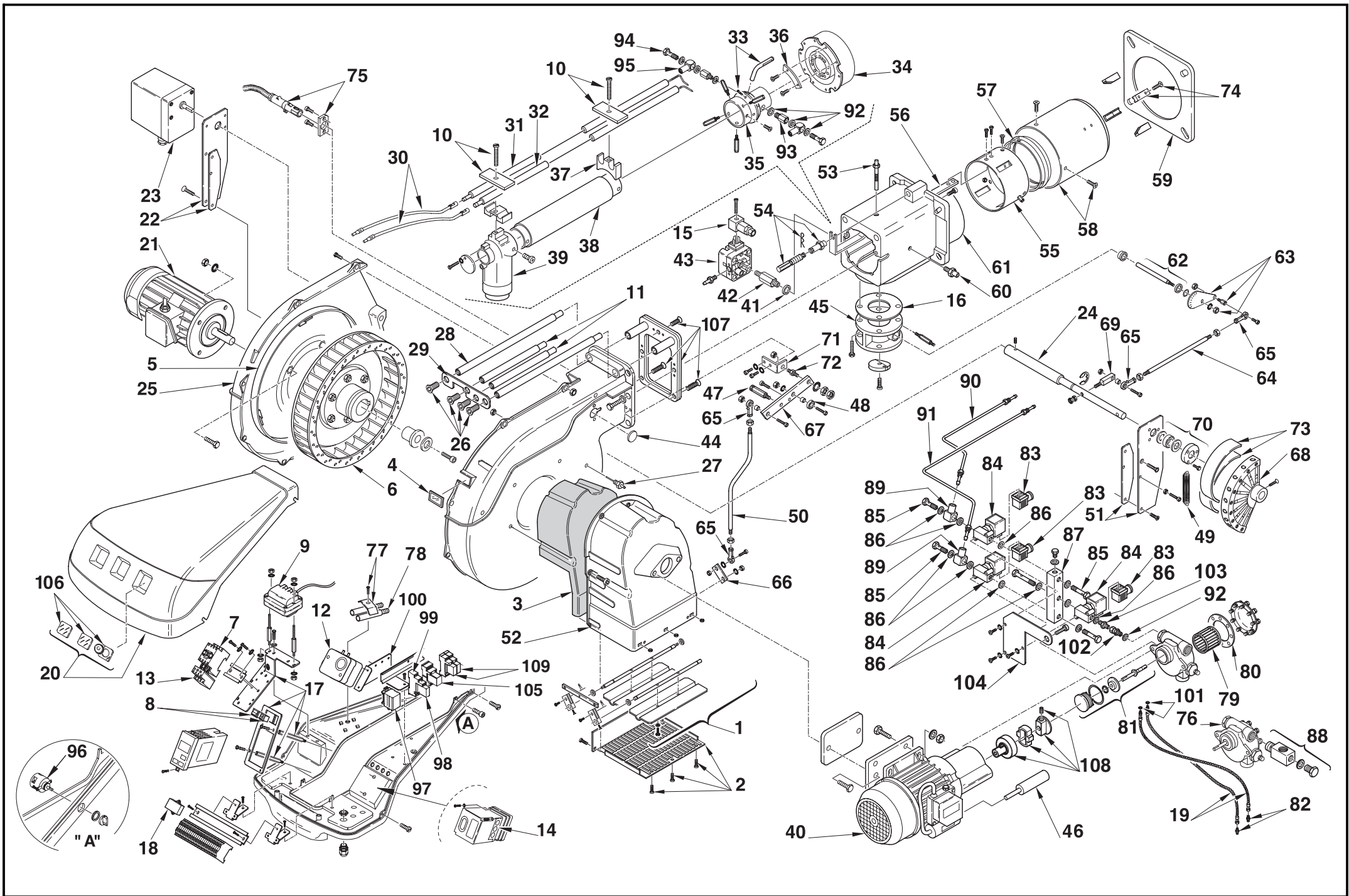

N.	COD.	3898200 - 3898210 3898201 - 3898211 * 20011632 - 20011635 20011641 - 20011642 *	DESCRIZIONE	DESCRIPTION	DESCRIPTION	BESCHREIBUNG	DENOMINACION	MATRICOLA BRUCIATORE BURNER SERIAL NUMBER MATRICULE BRULEUR BRENNER KENN-NUMMER MATRICULA QUEMADÓRES	**
1	3012583	• •	GRUPPO SERRANDA	AIR DAMPER ASSEMBLY	GROUPE VOLET AIR	LUFTKLAPPE	CONJUNTO REGISTRO AIRE	≤ 02356xxxxxx	
1	3013684	• •	GRUPPO SERRANDA	AIR DAMPER ASSEMBLY	GROUPE VOLET AIR	LUFTKLAPPE	CONJUNTO REGISTRO AIRE	≥ 02366xxxxxx	
1	3013684	• •	GRUPPO SERRANDA	AIR DAMPER ASSEMBLY	GROUPE VOLET AIR	LUFTKLAPPE	CONJUNTO REGISTRO AIRE		
2	3003086	• •	PROTEZIONE	GRID	PROTECTION	SCHUTZGITTER	PROTECION	≤ 02356xxxxxx	
2	3013683	• •	PROTEZIONE	GRID	PROTECTION	SCHUTZGITTER	PROTECION	≥ 02366xxxxxx	
2	3013683	• •	PROTEZIONE	GRID	PROTECTION	SCHUTZGITTER	PROTECION		
3	3012553	• •	FONOASSORBENTE	SOUND DAMPING	INSONORISANT	GERÄUSCHDÄMMUNG	AISLAMIENTO ACÚSTICO	≤ 02356xxxxxx	C
3	3013682	• •	FONOASSORBENTE	SOUND DAMPING	INSONORISANT	GERÄUSCHDÄMMUNG	AISLAMIENTO ACÚSTICO	≥ 02366xxxxxx	C
3	3013682	• •	FONOASSORBENTE	SOUND DAMPING	INSONORISANT	GERÄUSCHDÄMMUNG	AISLAMIENTO ACÚSTICO		C
4	3003763	• • • •	VISORE	INSPECTION WINDOW	VISEUR	SICHTFENSTER	VISOR		
5	3012573	• • • •	ANELLO	PISTON SEAL	JOINT TORIQUE	LIPPENDICHTUNG	RACORD		B
6	3012555	• • • •	GIRANTE	FAN	TURBINE	GEBLÄSERAD	TURBINA		C
7	3003637	• • • •	CONTATTORE	CONTACTOR	CONTACTEUR	SCHÜTZ	CONTACTOR	≤ 02179xxxxxx	C
7	3013978	• • • •	CONTATTORE	CONTACTOR	CONTACTEUR	SCHÜTZ	CONTACTOR	≥ 02189xxxxxx	C
7	3013978	• • • •	CONTATTORE	CONTACTOR	CONTACTEUR	SCHÜTZ	CONTACTOR		C
8	3012080	• • • •	INTERRUTTORE	SWITCH	INTERRUPTEUR	SCHALTER	INTERRUPTOR		C
9	3003785	• • • •	TRASFORMATORE	TRANSFORMER	TRANSFORMATEUR	ZÜNDTRANSFORMATOR	TRANSFORMADOR		B
10	3012626	• • • •	PIASTRINA	PLATE	PLAQUETTE ETRIER	PLATTE	PLATTE		
11	3012627	• •	PROLUNGA PERNO	BAR EXTENSION	RALLONGE DE GLISSIERE	VERLÄNGERUNG	PROLUNGACIÓN PERNO	≤ 02356xxxxxx	
11	3013686	• •	PROLUNGA PERNO	BAR EXTENSION	RALLONGE DE GLISSIERE	VERLÄNGERUNG	PROLUNGACIÓN PERNO	≥ 02366xxxxxx	
11	3013686	• •	PROLUNGA PERNO	BAR EXTENSION	RALLONGE DE GLISSIERE	VERLÄNGERUNG	PROLUNGACIÓN PERNO		
12	3007444	• • • •	PRESSOSTATO ARIA	AIR PRESSURE SWITCH	PRESSOSTAT AIR	LUFTDRUCKWÄCHTER	PRESÓSTATO AIRE		A
13	3013676	• •	RELÈ TERMICO	OVERLOAD	RELAIS THERMIQUE	ÜBERSTROMAUSLÖSER	RELÈ TERMICO	≤ 02179xxxxxx	C
13	3013980	• •	RELÈ TERMICO	OVERLOAD	RELAIS THERMIQUE	ÜBERSTROMAUSLÖSER	RELÈ TERMICO	≥ 02189xxxxxx	C
13	3013676	• •	RELÈ TERMICO	OVERLOAD	RELAIS THERMIQUE	ÜBERSTROMAUSLÖSER	RELÈ TERMICO		C
14	3006090	• • • •	APPARECCHIATURA	CONTROL BOX	BOITE DE CONTROLE	STEUERGERÄT	CAJA CONTROL		B
15	3012347	• • • •	PRESA	SOCKET	PRISE	STECKBUCHSE	CONECTOR		C
16	3005482	• • • •	GUARNIZIONE	SEAL	RONDELLE	FLANSCHDICHTUNG	JUNTA		B
17	3012343	• •	SUPPORTO	SUPPORT	SUPPORT	HALTER	SOPORTE	≤ 02179xxxxxx	
18	3012155	• • • •	FILTRO ANTIDISTURBO	DEGLITCHER	FILTRE	ENTSTÖRER	FILTRO ANTI- INTERFERENCIA		C

N.	COD.					DESCRIZIONE	DESCRIPTION	DESCRIPTION	BESCHREIBUNG	DENOMINACION	MATRICOLA BRUCIATORE BURNER SERIAL NUMBER MATRICULE BRULEUR BRENNER KENN-NUMMER MATRICULA QUEMADÓRES	**
		3898200 - 3898210	3898201 - 3898211 *	20011632 - 20011635	20011641 - 20011642 *							
19	3006182	•	•	•	•	TUBO FLESSIBILE	FLEXIBLE OIL LINE	FLEXIBLE	SCHLAUCH	TUBO FLEXIBLE		
20	3013119	•	•	•	•	COFANO	COVER	COFFRET	VERKLEIDUNG	ENVOLVENTE		
21	3012557	•	•	•	•	MOTORE	MOTOR	MOTEUR	MOTOR	MOTOR	C	
22	3012585	•	•	•	•	PIASTRA	ANCHOR PLATE	PLATINE DE BLOCAGE	ARRETIERPLATTE	PLACA		
23	3012345	•	•	•	•	SERVOMOTORE	SERVOMOTOR	SERVOMOTEUR	STELLMOTOR	SERVOMOTOR		
24	3012349	•	•	•	•	ALBERO	SHAFT	ARBRE	WELLE	ARBORILLO		
25	3012587	•	•	•	•	GUSCIO	HALF-SHELL	COUVERCLE	HAUBE	CÀSCARA		
26	3003481	•	•			VITE	SCREW	VIS	SCHRAUBE	TORNILLO	≤ 02356xxxxxx	
26	3013681	•	•			VITE	SCREW	VIS	SCHRAUBE	TORNILLO	≥ 02366xxxxxx	
26	3013681			•	•	VITE	SCREW	VIS	SCHRAUBE	TORNILLO		
27	3003891	•	•	•	•	RACCORDO	CONNECTOR	MAMELON	NIPPEL	RACORD	C	
28	3012628	•	•			PERNO	BAR	GLISSIERE	BOLZEN	PERNO	≤ 02356xxxxxx	
29	3012629	•	•			STAFFA	BRACKET	SUPPORT	KONSOLE	SOPORTE	≤ 02356xxxxxx	
30	3003795	•	•	•	•	COLLEGAMENTO ELETTRODO	H.T. LEAD	CONNEXION POUR ELECTRODE	VERBINDUNG FÜR ELEKTRODE	CABLE CONEXIÓN		
31	3013172	•		•		ELETTRODO	ELECTRODE	ELECTRODE PORCELAINE	ELEKTRODE	ELECTRODO	A	
31	3013173		•		•	ELETTRODO	ELECTRODE	ELECTRODE PORCELAINE	ELEKTRODE	ELECTRODO	A	
32	3013174	•		•		ELETTRODO	ELECTRODE	ELECTRODE PORCELAINE	ELEKTRODE	ELECTRODO	A	
32	3013175		•		•	ELETTRODO	ELECTRODE	ELECTRODE PORCELAINE	ELEKTRODE	ELECTRODO	A	
33	3013181	•	•	•	•	TUBETTO	TUBE	TUYAU	RÖHRCHEN	TUBO		
34	3013176	•	•	•	•	TAZZA	AIR DIFFUSER	DIFFUSEUR D'AIR	FLAMMKOPFBECHER	DIFUSOR DEL AIRE	A	
35	3013177	•	•	•	•	DISTRIBUTORE	GAS HEAD	DISTRIBUTEUR	GASVERTEILER	DISTRIBUIDOR		
36	3013178	•	•	•	•	PARZIALIZZATORE	SHUTTER	CLAPET	STAUSCHEIBE	ELICEPARCIALIZADORA		
37	3013179	•	•	•	•	SUPPORTO	SUPPORT	SUPPORT	HALTER	SOPORTE		
38	3012636	•		•		TUBO ESTERNO	EXTERIOR TUBE	TUYAU EXTERIEUR	AUSSERER ROHR	TUBO EXSTERNO		
38	3012920		•		•	TUBO ESTERNO	EXTERIOR TUBE	TUYAU EXTERIEUR	AUSSERER ROHR	TUBO EXSTERNO		
39	3012637	•	•	•	•	GOMITO	ELBOW	COUDE	SCHLITTEN	CODO		
40	3013180	•	•			MOTORE	MOTOR	MOTEUR	MOTOR	MOTOR	≤ 02436999999	
40	3013829	•	•			MOTORE	MOTOR	MOTEUR	MOTOR	MOTOR	≥ 02446000000	
40	3013829			•	•	MOTORE	MOTOR	MOTEUR	MOTOR	MOTOR	C	
41	3007088	•	•	•	•	GUARNIZIONE	SEAL	RONDELLE	METALLDICHTUNG	JUNTA	C	

N.	COD.	3898200 - 3898210 3898201 - 3898211 * 20011632 - 20011635 20011641 - 20011642 *	DESCRIZIONE	DESCRIPTION	DESCRIPTION	BESCHREIBUNG	DENOMINACION	MATRICOLA BRUCIATORE BURNER SERIAL NUMBER MATICULE BRULEUR BRENNER KENN-NUMMER MATRICULA QUEMADÓRES	**
42	3006615	• • • •	RACCORDO	CONNECTOR	MAMELON	NIPPEL	RACORD		C
43	3003660	• • • •	PRESSOSTATO GAS	GAS PRESSURE SWITCH	PRESSOSTAT GAZ	GAS DRUCKWÄCHTER	PRESÓSTATO GAS		B
44	3003996	• • • •	TAPPO	PLUG	BOUCHON A VIS	SCHRAUBSTÖPSEL	TAPÓN		
45	3006096	• • • •	REGOLATORE GAS	GAS REGULATOR	REGULATEUR GAZ	GAS REGLER	REGULACION GAS		C
46	3013182	• •	CONDENSATORE	CONDENSER	CONDENSATEUR	KONDENSATOR	CONDENSADOR	≤ 02436999999	B
46	3013875	• •	CONDENSATORE	CONDENSER	CONDENSATEUR	KONDENSATOR	CONDENSADOR	≥ 02446000000	B
46	3013875	• •	CONDENSATORE	CONDENSER	CONDENSATEUR	KONDENSATOR	CONDENSADOR		B
47	3012352	• • • •	PERNO	BAR	GLISSIERE	BOLZEN	PERNO		C
48	3003841	• • • •	CUSCINETTO	BEARING	ROULEMENT	LAGER	COJINETE		
49	3012356	• • • •	MOLLA	SPRING	RESSORT	FEDER	MUELLE		C
50	3012646	• • • •	TIRANTE	TIE ROD	TIRANT	GESTÄNGE	TIRANTE		C
51	3012594	• • • •	PIASTRA	ANCHOR PLATE	PLATINE DE BLOCAGE	ARRETIERPLATTE	PLACA		
52	3012828	• •	BOCCA D'ASPIRAZIONE	AIR INTAKE	BOITIER D'ASPIRATION	ANSAUGÖFFNUNG	BOCA DE ASPIRACIÓN	≤ 02356xxxxxx	
53	3012049	• • • •	VITE	SCREW	VIS	SCHRAUBE	TORNILLO		
54	3012639	• • • •	GRUPPO REGOLATORE	CONTROL DEVICE	GROUPE OBTURATION	DRUCKREGULIERUNG	GRUPO REGULACION		C
55	3012640	• • • •	CILINDRO	SLEEVE	CYLINDRE	ZYLINDER	CILINDRO		C
56	3012641	• •	STAFFA	BRACKET	SUPPORT	KONSOLE	SOPORTE		
56	3012922	• •	STAFFA	BRACKET	SUPPORT	KONSOLE	SOPORTE		
57	3012642	• • • •	OTTURATORE	SHUTTER	OBTURATEUR	SCHIEBER	OBTURADOR		C
58	3012643	• •	IMBUTO FIAMMA	END CONE	EMBOUT GUEULARD	FLAMMENROHR	TUBO EXTREMO		B
58	3012923	• •	IMBUTO FIAMMA	END CONE	EMBOUT GUEULARD	FLAMMENROHR	TUBO EXTREMO		B
59	3012562	• • • •	SCHERMO	FLANGE GASKET	ECRAN THERMIQUE	FLASCHDICHTUNG	JUNTA AISLANTE		A
60	3003322	• • • •	RACCORDO	CONNECTOR	MAMELON	NIPPEL	RACORD		C
61	3013184	• •	MANICOTTO	MANIFOLD	MANCHON	GASANSCHLUSS	COLARIN	≤ 02356xxxxxx	
62	3006132	• • • •	ALBERO E ANELLO	SHAFT AND RING	ARBRE ET ANNEAU	WELLE UND RING	ÁRBOLILLO Y ANILLO		C
63	3012644	• • • •	QUADRANTE	GRADUATE SECTOR	SECTEUR GRADUE	SKALENSEGMENT	SECTOR GRADUADO		
64	3012600	• •	TIRANTE	TIE ROD	TIRANT	GESTÄNGE	TIRANTE	≤ 02356xxxxxx	
64	3003543	• •	TIRANTE	TIE ROD	TIRANT	GESTÄNGE	TIRANTE	≥ 02366xxxxxx	
64	3003543	• •	TIRANTE	TIE ROD	TIRANT	GESTÄNGE	TIRANTE		
65	3006098	• • • •	SNODO SFERICO	PIN JOINT	CHAPE A ROTULE	KUGELGELENK	ARTICOLACION ESFERICA		C

N.	COD.	3898200 - 3898210 3898201 - 3898211 * 20011632 - 20011635 20011641 - 20011642 *				DESCRIZIONE	DESCRIPTION	DESCRIPTION	BESCHREIBUNG	DENOMINACION	MATRICOLA BRUCIATORE BURNER SERIAL NUMBER MATRICULE BRULEUR BRENNER KENN-NUMMER MATRICULA QUEMADÓRES	**
66	3012601	•	•	•	•	LEVA	LEVER	LEVIER	HEBEL	PALANCA		C
67	3012354	•	•	•	•	LEVA	LEVER	LEVIER	HEBEL	PALANCA		C
68	3012358	•	•	•	•	CAMMA	CAM	CAME	NOCKEN	EXCÉNTRICO		C
69	3012350	•	•	•	•	LEVA	LEVER	LEVIER	HEBEL	PALANCA		C
70	3012357	•	•	•	•	CUSCINETTO	BEARING	ROULEMENT	LAGER	COJINETE		
71	3012602	•	•	•	•	SUPPORTO	SUPPORT	SUPPORT	HALTER	SOPORTE		
72	3012603	•	•	•	•	PERNO	BAR	GLISSIERE	BOLZEN	PERNO		C
73	3006097	•	•	•	•	MOLLA	SPRING	RESSORT	FEDER	MUELLE		C
74	3012647	•	•	•	•	BASETTA	CENTERING SUPPORT	ELEMENT DE CENTRAGE	ZENTRIERHALTERUNG	SOPORTE		
75	3003396	•	•	•	•	FOTOCELLULA U.V.	DETECTOR	PHOTOCELLULE U.V.	U.V. PHOTOZELLE	FOTORESISTENCIA		A
76	3006369	•	•	•	•	POMPA	PUMP	POMPE	PUMPE	BOMBA		C
77	3003409	•				CAVALLOTTO	U BOLT	CAVALIER	BÜGELBOLZEN	FIJACION ELECTRODO	≤ 02356xxxxxx	
78	3003956	•				PROLUNGA PERNO	BAR EXTENSION	RALLONGE DE GLISSIERE	VERLÄNGERUNG	PROLUNGACIÓN PERNO	≤ 02356xxxxxx	
78	3013687	•				PROLUNGA PERNO	BAR EXTENSION	RALLONGE DE GLISSIERE	VERLÄNGERUNG	PROLUNGACIÓN PERNO	≥ 02366xxxxxx	
78	3013687			•		PROLUNGA PERNO	BAR EXTENSION	RALLONGE DE GLISSIERE	VERLÄNGERUNG	PROLUNGACIÓN PERNO		
79	3006787	•	•	•	•	FILTRO	FILTER	FILTRE	FILTER	FILTRO		A
80	3006292	•	•	•	•	GUARNIZIONE	SEAL	RONDELLE	METALLDICHTUNG	JUNTA		B
81	3000805	•	•	•	•	ORGANO DI TENUTA	PUMP SEAL	ORGANE D'ETANCHEITE	WELLENDICHTUNG	CONJUNTO ESTANQUIDAD		B
82	3006181	•	•	•	•	RACCORDO	CONNECTOR	MAMELON	NIPPEL	RACORD		C
83	3006953	•	•	•	•	PRESA	HOLDER	PRISE CELLULE	SOCKEL	CONECTOR		B
84	3012002	•	•	•	•	VALVOLA	NEEDLEVALVE	VANNE POINTEAU	NADELVENTIL	VÀLVULA		
85	3003592	•	•	•	•	PERNO	BAR	GLISSIERE	BOLZEN	PERNO		C
86	3007077	•	•	•	•	GUARNIZIONE	SEAL	RONDELLE	METALLDICHTUNG	JUNTA		B
87	3012569	•	•	•	•	COLLETTORE	MANIFOLD	COLLECTEUR	SAMMLER	COLECTOR		C
88	3003681	•	•	•	•	RACCORDO	CONNECTOR	MAMELON	NIPPEL	RACORD		C
89	3006722	•	•	•	•	RACCORDO	CONNECTOR	MAMELON	NIPPEL	RACORD		C
90	3013186	•				TUBO	TUBE	TUYAUTERIE	DRUCKROHR	TUBO	≤ 02126999999	
90	3013666	•				TUBO	TUBE	TUYAUTERIE	DRUCKROHR	TUBO	≥ 02136000001; ≤ 02356xxxxxx	
90	3013688	•				TUBO	TUBE	TUYAUTERIE	DRUCKROHR	TUBO	≥ 02366xxxxxx	
90	3013688		•			TUBO	TUBE	TUYAUTERIE	DRUCKROHR	TUBO		

N.	COD.	3898200 - 3898210 3898201 - 3898211 * 20011632 - 20011635 20011641 - 20011642 *	DESCRIZIONE	DESCRIPTION	DESCRIPTION	BESCHREIBUNG	DENOMINACION	MATRICOLA BRUCIATORE BURNER SERIAL NUMBER MATRICULE BRULEUR BRENNER KENN-NUMMER MATRICULA QUEMADÓRES	**
90	3013191	•	TUBO	TUBE	TUYAUTERIE	DRUCKROHR	TUBO	≤ 02126999999	
90	3013667	•	TUBO	TUBE	TUYAUTERIE	DRUCKROHR	TUBO	≥ 02136000001; ≤ 02356xxxxxx	
90	3013689	•	TUBO	TUBE	TUYAUTERIE	DRUCKROHR	TUBO	≥ 02366xxxxxx	
90	3013689	•	TUBO	TUBE	TUYAUTERIE	DRUCKROHR	TUBO		
91	3013187	•	TUBO	TUBE	TUYAUTERIE	DRUCKROHR	TUBO	≤ 02126999999	
91	3013668	•	TUBO	TUBE	TUYAUTERIE	DRUCKROHR	TUBO	≥ 02136000001; ≤ 02356xxxxxx	
91	3013690	•	TUBO	TUBE	TUYAUTERIE	DRUCKROHR	TUBO	≥ 02366xxxxxx	
91	3013690	•	TUBO	TUBE	TUYAUTERIE	DRUCKROHR	TUBO		
91	3013192	•	TUBO	TUBE	TUYAUTERIE	DRUCKROHR	TUBO	≤ 02126999999	
91	3013669	•	TUBO	TUBE	TUYAUTERIE	DRUCKROHR	TUBO	≥ 02136000001; ≤ 02356xxxxxx	
91	3013691	•	TUBO	TUBE	TUYAUTERIE	DRUCKROHR	TUBO	≥ 02366xxxxxx	
91	3013691	•	TUBO	TUBE	TUYAUTERIE	DRUCKROHR	TUBO		
92	3007079	• • • •	GUARNIZIONE	SEAL	RONDELLE	METALLDICHTUNG	JUNTA		B
93	3013188	• • • •	RACCORDO	CONNECTOR	MAMELON	NIPPEL	RACORD		C
94	3003006	• • • •	PERNO	BAR	GLISSIERE	BOLZEN	PERNO		C
95	3006784	• • • •	RACCORDO	CONNECTOR	MAMELON	NIPPEL	RACORD		C
96	3012310	• • • •	COMMUTATORE	SELECTOR SWITCH	COMMUTATOR	WAHLSCHALTER	CONMUTADOR		
97	3013526	• • • •	RELÈ	RELAY	RELAIS	RELAIS	RELÉ		
98	3012368	• • • •	RELÈ	RELAY	RELAIS	RELAIS	RELÉ		
99	3003935	• • • •	ZOCCOLO	CONTROL BOX BASE	SOCLE	SOCKEL	ZOCALO		
100	3014216	• • • •	SUPPORTO	SUPPORT	SUPPORT	HALTER	CORCHETE		
101	3007164	• •	GUARNIZIONE	SEAL	RONDELLE	METALLDICHTUNG	JUNTA	≥ 02136000001	B
101	3007164	• •	GUARNIZIONE	SEAL	RONDELLE	METALLDICHTUNG	JUNTA		B
102	3013462	• •	RACCORDO GIREVOLE	SWIVEL FITTING	TOURNANT	DREHANSCHLUSS	EMPALME GIRATORIO	≥ 02136000001	C
102	3013462	• •	RACCORDO GIREVOLE	SWIVEL FITTING	TOURNANT	DREHANSCHLUSS	EMPALME GIRATORIO		C
103	3013185	• •	RACCORDO	CONNECTOR	MAMELON	NIPPEL	RACORD	≥ 02136000001	C
103	3013185	• •	RACCORDO	CONNECTOR	MAMELON	NIPPEL	RACORD		C
104	3013671	• • • •	STAFFA	BRACKET	SUPPORT	KONSOLE	SOPORTE		
105	3014157	• • • •	RELÈ + ZOCCOLO	RELAY + BASE	RELAIS + SOCLE	RELAIS + SOCKEL	RELÉ + ZOCALO		

N.	COD.	3898200 - 3898210 3898201 - 3898211 * 20011632 - 20011635 20011641 - 20011642 *	DESCRIZIONE	DESCRIPTION	DESCRIPTION	BESCHREIBUNG	DENOMINACION	MATRICOLA BRUCIATORE BURNER SERIAL NUMBER MATRICULE BRULEUR BRENNER KENN-NUMMER MATRICULA QUEMADÓRES	**
106	3013678	• • • •	MEMBRANA+VETRINO	MEMBRANE+VIEWING PORT	MEMBRANE+REGARD	MEMBRAN+VERSCHLUßSTO PFEN	MEMBRANA+MIRILLA		
107	3013685	• • • •	GRUPPO PIASTRE	PLATES ASSEMBLY	GROUPE PLATINES	PLATTENGRUPPE	CONJUNTO PLACAS	≥ 02366xxxxxx	
107	3013685	• • • •	GRUPPO PIASTRE	PLATES ASSEMBLY	GROUPE PLATINES	PLATTENGRUPPE	CONJUNTO PLACAS		
108	3013828	• • • •	GIUNTO	JOINT	ACCOUPLMENT	PUMPENKUPPLUNG	ACOPLAMIENTO		A
109	3013407	• • • •	RELÈ + ZOCCOLO	RELAY + BASE	RELAIS + SOCLE	RELAIS + SOCKEL	RELÉ + ZOCALO		

* = Versione Testa Lunga - Long Combustion Head Version - Version Tête Longue - Langer Brennkopf Ausführung - Versión alargado de tubo llama

**

RICAMBI CONSIGLIATI - ADVISED PARTS - RECHANGE CONSEIL - EMPFOHLENE ERSATZTEILE - RECAMBIOS ACONSEJADOS

A = Ricambi per dotazione minima - Spare parts for minimum fittings - Pièces détachées pour équipement minimum - Ersatzteile für minimale Ausstattung - Recambios para equipamiento mínimo

A+B = Ricambi per dotazione base di sicurezza - Spare parts for basic safety fittings - Pièces détachées pour équipement standard de sécurité - Ersatzteile für Sicherheitsgrundausrüstung - Recambios para equipamiento básico de seguridad

A+B+C = Ricambi per dotazione estesa di sicurezza - Spare parts for extended safety fittings - Pièces détachées pour équipement complet de sécurité - Ersatzteile für erweiterte Sicherheitsausrüstung - Recambios para equipamiento general de seguridad

RIELLO

RIELLO S.p.A.
I-37045 Legnago (VR)
Tel.: +39.0442.630111
[http:// www.riello.it](http://www.riello.it)
[http:// www.rielloburners.com](http://www.rielloburners.com)