

- I** Bruciatori di gasolio
- GB** Light oil burners
- F** Brûleurs fioul domestique
- D** Öl-Gebläsebrenner
- E** Quemadores de gasóleo

Funzionamento bistadio  
Two-stage operation  
Fonctionnement à deux allures  
Zweistufiger Betrieb  
Funcionamiento a dos llama

<b>CODICE - CODE CÓDIGO</b>	<b>MODELLO - MODEL - MODELE MODELL - MODELO</b>	<b>TIPO - TYPE - TYP</b>
3475612 - 3475613	RL 190	673 T1
20011006 - 20011008	RL 190	673 T1

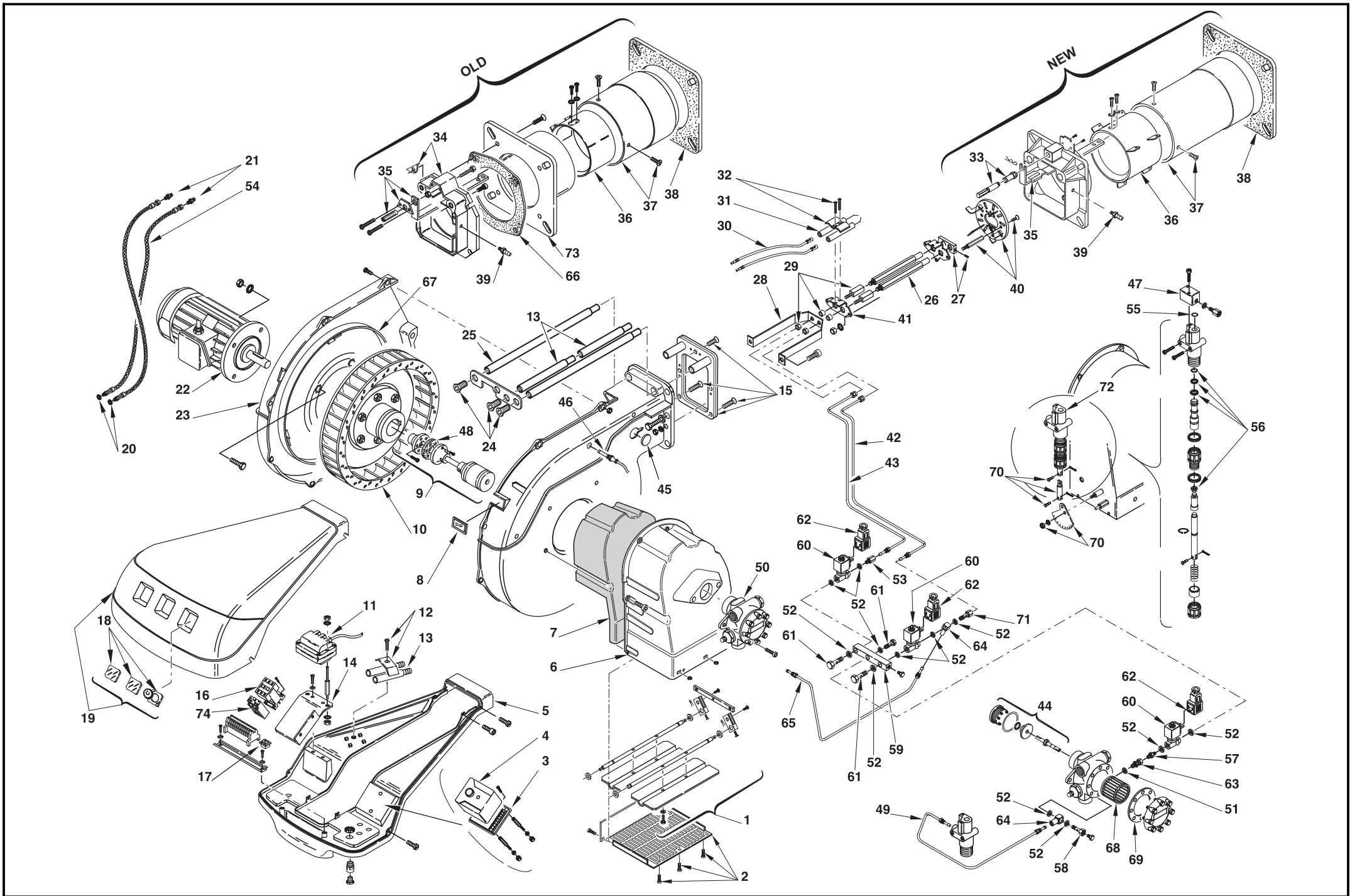

N.	COD.	3475612 - 3475613 20011006 - 20011008	DESCRIZIONE	DESCRIPTION	DESCRIPTION	BESCHREIBUNG	DENOMINACION	MATRICOLA BRUCIATORE BURNER SERIAL NUMBER MATRICULE BRULEUR BRENNER KENN-NUMMER MATRICULA QUEMADÓRES	*
1	3012551	•	GRUPPO SERRANDA	AIR DAMPER ASSEMBLY	GROUPE VOLET AIR	LUFTKLAPPE	CONJUNTO REGISTRO AIRE	≤ 02406xxxxxx	
1	3013859	•	GRUPPO SERRANDA	AIR DAMPER ASSEMBLY	GROUPE VOLET AIR	LUFTKLAPPE	CONJUNTO REGISTRO AIRE	≥ 02416xxxxxx	
1	3013859	•	GRUPPO SERRANDA	AIR DAMPER ASSEMBLY	GROUPE VOLET AIR	LUFTKLAPPE	CONJUNTO REGISTRO AIRE		
2	3003086	•	PROTEZIONE	GRID	PROTECTION	SCHUTZGITTER	PROTECION	≤ 02406xxxxxx	
2	3013683	•	PROTEZIONE	GRID	PROTECTION	SCHUTZGITTER	PROTECION	≥ 02416xxxxxx	
2	3013683	•	PROTEZIONE	GRID	PROTECTION	SCHUTZGITTER	PROTECION		
3	3003784	• •	MORSETTIERA	CONTROL BOX BASE	SOCLE	STECKSOCKEL	ZOCALO CAJA CONTROL		C
4	3013071	• •	APPARECCHIATURA	CONTROL BOX	BOITE DE CONTROLE	STEUERGERÄT	CAJA CONTROL		A
5	3012008	•	MENSOLA	BASE PLATE	PLAQUE DE SUPPORT	GRUNDPLATTE	REPISA	≤ 02188xxxxxx	
5	3014124	•	MENSOLA	BASE PLATE	PLAQUE DE SUPPORT	GRUNDPLATTE	REPISA	≥ 02198xxxxxx	
5	3014124	•	MENSOLA	BASE PLATE	PLAQUE DE SUPPORT	GRUNDPLATTE	REPISA		
6	3012552	•	BOCCA D'ASPIRAZIONE	AIR INTAKE	BOITIER D'ASPIRATION	ANSAUGÖFFNUNG	BOCA ASPIRACION	≤ 02406xxxxxx	
7	3012553	•	FONOASSORBENTE	SOUND DAMPING	INSONORISANT	GERÄUSCHDÄMMUNG	AISLAMIENTO ACUSTICO	≤ 02406xxxxxx	
7	3013682	•	FONOASSORBENTE	SOUND DAMPING	INSONORISANT	GERÄUSCHDÄMMUNG	AISLAMIENTO ACUSTICO	≥ 02416xxxxxx	
7	3013682	•	FONOASSORBENTE	SOUND DAMPING	INSONORISANT	GERÄUSCHDÄMMUNG	AISLAMIENTO ACUSTICO		
8	3003763	• •	VISORE	INSPECTION WIN	WISEUR	SICHTFENSTER	VISOR		
9	3012554	• •	GRUPPO GIUNZIONE	DRIVE COUPLING	ACCOUPEMENT	KUPPLUNG	ACOPLADOR IMPULSOR		A
10	3012555	• •	GIRANTE	FAN	TURBINE	GEBLÄSERAD	TURBINA		C
11	3012488	• •	TRASFORMATORE	TRANSFORMER	TRANSFORMATEUR	ZÜNDTRANSFORMATOR	TRANSFORMADOR		B
12	3003409	•	CAVALLOTTO	U BOLT	CAVALIER	BÜGELBOLZEN	FIJACION ELECTRODO	≤ 02406xxxxxx	
13	3003956	•	PROLUNGA PERNO	BAR EXTENSION	RALLONGE DE GLISSIERE	VERLÄNGERUNG	PROLUNGACION PERNO	≤ 02406xxxxxx	
13	3013687	•	PROLUNGA PERNO	BAR EXTENSION	RALLONGE DE GLISSIERE	VERLÄNGERUNG	PROLUNGACION PERNO	≥ 02416xxxxxx	
13	3013687	•	PROLUNGA PERNO	BAR EXTENSION	RALLONGE DE GLISSIERE	VERLÄNGERUNG	PROLUNGACION PERNO		
14	3003957	•	SUPPORTO	SUPPORT	SUPPORT	HALTER	SOPORTE	≤ 02179xxxxxx	
15	3013685	•	GRUPPO PIASTRE	PLATES ASSEMBLY	GROUPE PLATINES	PLATTEN GROUPE	CONJUNTO PLACAS	≥ 02416xxxxxx	
15	3013685	•	GRUPPO PIASTRE	PLATES ASSEMBLY	GROUPE PLATINES	PLATTEN GROUPE	CONJUNTO PLACAS		
16	3012556	•	RELE' TERMICO + CONTATTORE	OVERLOAD + CONTACTOR	RELAIS THERMIQUE + CONTACTEUR	ÜBERSTROMAUSLÖSER + SCHÜTZ	RÉLE TÉRMICO + CONTACTOR	≤ 02179xxxxxx	C
16	3013978	•	CONTATTORE	CONTACTOR	CONTACTEUR	SCHÜTZ	CONTACTOR	≥ 02189xxxxxx	C
16	3013978	•	CONTATTORE	CONTACTOR	CONTACTEUR	SCHÜTZ	CONTACTOR		C
17	3003770	• •	INTERRUTTORE	SWITCH	INTERRUPTEUR	SCHALTER	INTERRUPTOR		C

N.	COD.	3475612 - 3475613 20011006 - 20011008	DESCRIZIONE	DESCRIPTION	DESCRIPTION	BESCHREIBUNG	DENOMINACION	MATRICOLA BRUCIATORE BURNER SERIAL NUMBER MATICULE BRULEUR BRENNER KENN-NUMMER MATICULA QUEMADORES	*
18	3013678	• •	MEMBRANA + VETRINO	MEMBRANE+VIEWING PORT	MEMBRANE+REGARD	MEMBRAN+VERSCHLUßS- TOPFEN	MEMBRANA+MIRILLA		
19	3013119	• •	COFANO	COVER	COFFRET	VERKLEIDUNG	ENVOLVENTE		
20	3007164	• •	GUARNIZIONE	SEAL	RONDELLE	METALLDICHTUNG	JUNTA		B
21	3006181	• •	RACCORDO	CONNECTOR	MAMELON	NIPPEL	RACORD		C
22	3012557	• •	MOTORE	MOTOR	MOTEUR	MOTOR	MOTOR		C
23	3012558	• •	GUSCIO	HALF-SHELL	COUVERCLE	HAUBE	CASCARA		
24	3003481	•	VITE	SCREW	VIS	SCHRAUBE	TORNILLO	≤ 02406xxxxxx	
24	3013681	•	VITE	SCREW	VIS	SCHRAUBE	TORNILLO	≥ 02416xxxxxx	
24	3013681	•	VITE	SCREW	VIS	SCHRAUBE	TORNILLO		
25	3003970	•	PERNO	BAR	GLISSIERE	BOLZEN	PERNO	≤ 02406xxxxxx	
26	3003789	• •	PROLUNGA PERNO	BAR EXTENSION	RALLONGE DE GLISSIERE	VERLÄNGERUNG	PROLUNGACION PERNO		
27	3003790	• •	PIASTRA	ANCHOR PLATE	PLATINE DE BLOCAGE	ARRETIERPLATTE	PLACA		
28	3003971	• •	SUPPORTO	SUPPORT	SUPPORT	HALTER	SOPORTE		
29	3003814	• •	PORTASPRUZZO	NOZZLE HOLDER	PULVERISATEUR	DÜSENSTOCK	PORTABOQUILLA		C
30	3003973	• •	COLLEGAMENTO	H.T. LEAD	CABLE H.T.	ZÜNDKABEL	CABLES ELECTRODOS		A
31	3003796	• •	ELETTRODO	ELECTRODE	ELECTRODE PORCELAINE	ELEKTRODE	ELECTRODO		A
32	3003495	• •	CAVALLOTTO	U BOLT	CAVALIER	BÜGELBOLZEN	FIJACION ELECTRODO		
33	3012639	•	GRUPPO REGOLATORE	CONTROL DEVICE	GROUPE OBTURATION	DRUCKREGULIERUNG	GRUPO REGULACION	≥ 02416xxxxxx	C
33	3012639	•	GRUPPO REGOLATORE	CONTROL DEVICE	GROUPE OBTURATION	DRUCKREGULIERUNG	GRUPO REGULACION		C
34	3013165	•	FRONTONE	FRONT PIECE	FACADE	VORDERTEIL	SOPORTE QUEMADORE	≤ 02406xxxxxx	
35	3003982	•	SQUADRETTA	SQUARE	EQUERRE-SUPPORT	HALTER	ESQUADRA	≤ 02406xxxxxx	
35	3013698	•	SQUADRETTA	SQUARE	EQUERRE-SUPPORT	HALTER	ESQUADRA	≥ 02416xxxxxx	
35	3013698	•	SQUADRETTA	SQUARE	EQUERRE-SUPPORT	HALTER	ESQUADRA		
36	3012560	• •	OTTURATORE	SHUTTER	OBTURATEUR	SCHIEBER	OBTURADOR		C
37	3012561	•	IMBUTO FIAMMA	END CONE	EMBOUT GUEULARD	FLAMMENROHR	TUBO EXTREMO	≤ 02406xxxxxx	B
37	3013760	•	IMBUTO FIAMMA	END CONE	EMBOUT GUEULARD	FLAMMENROHR	TUBO EXTREMO	≥ 02416xxxxxx	B
37	3013760	•	IMBUTO FIAMMA	END CONE	EMBOUT GUEULARD	FLAMMENROHR	TUBO EXTREMO		B
38	3012562	• •	SCHERMO	FLANGE GASKET	ECRAN THERMIQUE	FLANSCHDICHTUNG	JUNTA AISLANTE		A
39	3003322	• •	RACCORDO	CONNECTOR	MAMELON	NIPPEL	RACORD		C
40	3012563	• •	ELICA	DIFFUSER DISC	ACCROCHE FLAMME	STAUSCHEIBE	DISCO ESTABILIZADOR		A

N.	COD.	3475612 - 3475613 20011006 - 20011008	DESCRIZIONE	DESCRIPTION	DESCRIPTION	BESCHREIBUNG	DENOMINACION	MATRICOLA BRUCIATORE BURNER SERIAL NUMBER MATICULE BRULEUR BRENNER KENN-NUMMER MATRICULA QUEMADÓRES	*
41	3003815	• •	SUPPORTO	SUPPORT	SUPPORT	HALTER	SOPORTE		
42	3012564	• •	TUBO	TUBE	TUYAUTERIE	DRUCKROHR	TUBO	≤ 02406xxxxxx	
42	3013857	• •	TUBO	TUBE	TUYAUTERIE	DRUCKROHR	TUBO	≥ 02416xxxxxx	
42	3013857	• •	TUBO	TUBE	TUYAUTERIE	DRUCKROHR	TUBO		
43	3012565	• •	TUBO	TUBE	TUYAUTERIE	DRUCKROHR	TUBO	≤ 02406xxxxxx	
43	3013858	• •	TUBO	TUBE	TUYAUTERIE	DRUCKROHR	TUBO	≥ 02416xxxxxx	
43	3013858	• •	TUBO	TUBE	TUYAUTERIE	DRUCKROHR	TUBO		
44	3000805	• •	ORGANO DI TENUTA	PUMP SEAL	ORGANE D'ETANCHEITE	WELLENDICHTUNG	CONJUNTO ESTANQUIDAD		
45	3003996	• •	TAPPO	PLUG	BOUCHON A VIS	SCHRAUBSTÖPSEL	TAPÓN		A
46	3013708	• •	FOTORESISTENZA	P.E. CELL	CELLULE	FOTOWIDERSTAND	FOTORESISTENCIA		A
47	3012566	• •	COLLETTORE	MANIFOLD	COLLECTEUR	SAMMLER	COLECTOR		
48	3004821	• •	DISCO ELASTICO	DRIVE DISC	DISQUE ELASTIQUE	KUPPLUNGSSCHEIBE	DISCO ELASTICO		A
49	3012567	• •	TUBO	TUBE	TUYAUTERIE	DRUCKROHR	TUBO		
50	3006369	• •	POMPA	PUMP	POMPE	PUMPE	BOMBA		C
51	3007079	• •	GUARNIZIONE	SEAL	RONDELLE	METALLDICHTUNG	JUNTA		B
52	3007077	• •	GUARNIZIONE	SEAL	RONDELLE	METALLDICHTUNG	JUNTA		B
53	3006719	• •	RACCORDO	CONNECTOR	MAMELON	NIPPEL	RACORD		C
54	3006182	• •	TUBO FLESSIBILE	TUBE	TUYAUTERIE	DRUCKROHR	TUBO FLEXIBLE		A
55	3003823	• •	ANELLO	PISTON SEAL	JOINT TORIQUE	LIPPENDICHTUNG	ANILLO		B
56	3003820	• •	ANELLO	PISTON SEAL	JOINT TORIQUE	LIPPENDICHTUNG	ANILLO		B
57	3012568	• •	RACCORDO	CONNECTOR	MAMELON	NIPPEL	RACORD		C
58	3012003	• •	PERNO	SCREW	VIS CREUSE	HOHLKERNSCHRAUBE	PERNO		C
59	3012569	• •	COLLETTORE	MANIFOLD	COLLECTEUR	SAMMLER	COLECTOR		
60	3012570	• •	VALVOLA	SOLENOID VALVE	SOUPAPE ELECTRIQUE	ELEKTROVENTIL	VALVULA		B
61	3006721	• •	PERNO	SCREW	VIS CREUSE	HOHLKERNSCHRAUBE	PERNO		C
62	3006953	• •	PRESA	SOCKET	PRISE	STECKERBUCHSE	CONNECTOR MACHO		C
63	3012547	• •	RACCORDO	CONNECTOR	MAMELON	NIPPEL	RACORD		C
64	3006722	• •	RACCORDO	CONNECTOR	MAMELON	NIPPEL	RACORD		C
65	3012571	• •	TUBO	TUBE	TUYAUTERIE	DRUCKROHR	TUBO		
66	3012572	• •	SCHERMO	FLANGE GASKET	ECRAN THERMIQUE	FLANSCHDICHTUNG	JUNTA AISLANTE	≤ 02406xxxxxx	A
67	3012573	• •	ANELLO	PISTON SEAL	JOINT TORIQUE	LIPPENDICHTUNG	ANILLO		B

N.	COD.	3475612 - 3475613 20011006 - 20011008	DESCRIZIONE	DESCRIPTION	DESCRIPTION	BESCHREIBUNG	DENOMINACION	MATRICOLA BRUCIATORE BURNER SERIAL NUMBER MATRICULE BRULEUR BRENNER KENN-NUMMER MATRICULA QUEMADÓRES	*
68	3006787	• •	FILTRO	FILTER	FILTRE	PUMPENFILTER	FILTRO		A
69	3006292	• •	GUARNIZIONE	SEAL	RONDELLE	PUMPENDICHTUNG	JUNTA		A
70	3012574	• •	QUADRANTE	GRADUATE SECTOR	SECTEUR GRADUE	SKALENSEGMENT	SECTOR GRADUADO		
71	3012575	• •	PERNO	SCREW	VIS CREUSE	HOHLKERNSCHRAUBE	PERNO		C
72	3003825	• •	MARTINETTO	HYDRAULIC JACK	VERIN AIR	DRUCKKOLBEN FÜR LUFTK- LAPPE	HIDRAULICO DE AIRE		C
73	3012576	•	BOCCAGLIO	BLAST TUBE	GUEULARD	BRENNERFLANSCH	TUBO LLAMA	≤ 02406xxxxxx	
74	3013980	•	RELÈ TERMICO	OVERLOAD	RELAIS THERMIQUE	ÜBERSTROMAUSLÖSER	RELÈ TERMICO	≥ 02189xxxxxx	C
74	20011593	•	RELÈ TERMICO	OVERLOAD	RELAIS THERMIQUE	ÜBERSTROMAUSLÖSER	RELÈ TERMICO		C

\*

**RICAMBI CONSIGLIATI - ADVISED PARTS - RECHANGE CONSEIL - EMPFOHLENE ERSATZTEILE - RECAMBIOS ACONSEJADOS**

A = Ricambi per dotazione minima - Spare parts for minimum fittings - Pièces détachées pour équipement minimum - Ersatzteile für minimale Ausstattung - Recambios para equipamiento mínimo

A+B = Ricambi per dotazione base di sicurezza - Spare parts for basic safety fittings - Pièces détachées pour équipement standard de sécurité - Ersatzteile für Sicherheitsgrundausrüstung - Recambios para equipamiento básico de seguridad

A+B+C = Ricambi per dotazione estesa di sicurezza - Spare parts for extended safety fittings - Pièces détachées pour équipement complet de sécurité - Ersatzteile für erweiterte Sicherheitsausstattung - Recambios para equipamiento general de seguridad



---

**RIELLO**

RIELLO S.p.A.  
I-37045 Legnago (VR)  
Tel.: +39.0442.630111  
[http:// www.riello.it](http://www.riello.it)  
[http:// www.rielloburners.com](http://www.rielloburners.com)